



Huawei CloudEngine 9860 Switch Datasheet

Huawei CloudEngine 9860 series switches provide high-density 400GE/100GE ports and high performance.

Product Overview

Huawei CloudEngine 9860 series switches are 400GE/100G Ethernet switches designed for data centers networks. The switches provide high-performance, high-density 100GE ports, and low latency. Using the Huawei VRP8 software platform, CloudEngine 9860 series switches provide extensive data center service features. CloudEngine 9860 series switches can work with CloudEngine 16800/CloudEngine 12800/CloudEngine 8800/CloudEngine 6800/CloudEngine 5800 switches to build an elastic, virtualized, high-quality fabric that meets the requirements of cloud-computing data centers.

CloudEngine 9860 series switches can function as core or aggregation switches on data center networks to help enterprises and carriers build a scalable data center network platform in the cloud computing era.

Product Appearance

CloudEngine 9860-4C-EI supports four flexible cards and provides 32*400GE QSFP-DD ports or 128*100GE QSFP28 ports or other combination.



The CloudEngine 9860 series switches support the following models of cards.

CE98-D32CQ card: 32*100GE (QSFP28):



CE98-D8DQ card: 8*400GE (QSFP-DD):



Product Characteristics

High-Density 400GE/100GE/40GE Aggregation and Outstanding Switching Capacity

- The CloudEngine 9860 provides 25.6 Tbps switching capacity, forwarding performance of 7,600 Mpps, and supports L2/L3 line-speed forwarding.
- The CloudEngine 9860 provides a maximum of 32*400GE QSFP-DD or 128*100GE QSFP28 or 128*40GE QSFP+ ports, and can function as the core or aggregation switch on a data center or campus network.
- The 100GE QSFP28 port supports 100GE optical modules. The 100GE QSFP28 port also supports 40GE QSFP+ optical modules.

Network-Wide Reliability, Ensuring Zero Service Interruptions

- The CloudEngine 9860 series switches support multichassis link aggregation group (M-LAG), which enables links of multiple switches to aggregate into one to implement device-level link backup.
- Switches in an M-LAG system can be upgraded independently. During the upgrade, other switches in the system take over traffic forwarding to ensure uninterrupted services.

Programmable Network Device, Flexible Customization

- The CloudEngine 9860 series switches use the Open Programmability System (OPS) embedded in the VRP8 software platform to provide programmability at the control plane.
- The OPS provides open APIs. APIs can be integrated with mainstream cloud platforms (including commercial and open cloud platforms) and third-party controllers. The OPS enables services to be flexibly customized and provides automatic management.
- Users or third-party developers can use open APIs to develop and deploy specialized network management policies to implement extension of fast service functions, automatic deployment, and intelligent management. The OPS also implements automatic operation and maintenance, and reduces management costs.
- The OPS provides seamless integration of data center service and network in addition to a service-oriented, software-defined networking (SDN).

Intelligent Lossless Networking, Meeting High Performance Requirements of RoCEv2 Applications

- The CloudEngine 9860 series support iLossless algorithm which prevents packet loss caused by traffic congestion on traditional Ethernet and helps build a network environment featuring zero packet loss, low latency, and high throughput for RoCEv2 traffic. This meets high performance requirements of RoCEv2 applications.
- The CloudEngine 9860 series support PFC deadlock prevention which identifies service flows that easily cause PFC deadlocks and changes queue priorities to prevent PFC deadlocks.
- The CloudEngine 9860 series support Artificial Intelligence Explicit Congestion Notification (AI ECN) which intelligently adjusts ECN thresholds of lossless queues based on the live-network traffic model. This ensures low delay, high throughput, and zero packet loss, delivering optimal performance for lossless services.

Intelligent O&M Through Cooperation with iMaster NCE-FabricInsight

- Telemetry: collects device data in real time and sends the data to iMaster NCE-FabricInsight, which is a DCN analysis component of Huawei iMaster NCE. iMaster NCE-FabricInsight uses an intelligent fault identification algorithm to analyze network data and accurately display the network status in real time. In addition, iMaster NCE-FabricInsight can effectively demarcate faults and locate fault causes in a timely manner to identify network issues that deteriorate user experience, guaranteeing superb user experience.
- Intelligent traffic analysis: enables the switch to perform in-depth analysis on a specified service flow to obtain data about high-precision performance indicators such as the packet loss rate and latency (nanosecond-level) of the service flow. The switch can send the analysis result to iMaster NCE-FabricInsight for graphical display. This makes it easier for O&M personnel to monitor the network running status and quickly locate network faults.

ZTP, Implementing Automatic O&M

- The CloudEngine 9860 series switches support Zero Touch Provisioning (ZTP). ZTP enables the CloudEngine 9860 to automatically obtain and load version files from a USB flash drive or file server, freeing network engineers from onsite configuration or deployment. ZTP reduces labor costs and improves device deployment efficiency.
- ZTP provides built-in scripts for users through open APIs. Data center personnel can use the programming language they are familiar with, such as Python, to provide unified configuration of network devices.
- ZTP decouples configuration time of new devices from device quantity and area distribution, which improves service provisioning efficiency.

Standard Back-to-front Airflow Design, High Energy Efficiency

Standard Back-to-front airflow design

- The CloudEngine 9860 series switches use a back-to-front airflow design that isolates cold air channels from hot air channels. This design meets heat dissipation requirements in data center equipment rooms.

- Air can flow from back to front depending on the fans and power modules that are used.
- Redundant power modules and fans can be configured to ensure service continuity.

Innovative energy-saving technologies

- The CloudEngine 9860 series switches have energy-saving chips and can measure system power consumption in real time. Fan speed can be adjusted dynamically based on system consumption. These energy-saving technologies reduce O&M costs and contribute to a greener data center.

Clear Indicators, Simplifying Maintenance

Clear indicators

- Port indicators clearly show the port status and port rate. The 100GE port indicators can show the states of all ports derived from the 100GE ports.
- State indicators on both the front and rear panels enable users to maintain the switch from either side.
- The CloudEngine 9860 series switches support remote positioning. Operators can turn on remote positioning indicators on the switches they want to maintain, so that they can find switches easily in an equipment room full of devices.

Simple maintenance

- The management port, fans, and power modules are on the front panel, which facilitates device maintenance.
- Data ports are located at the rear, facing servers. This simplifies cabling.

Licensing

CloudEngine 9860 supports Huawei IDN One Software (N1 mode for short) licensing mode. The CloudFabric N1 business model simplifies transactions, provides customers with more functions and value, and protects their software investment with Software License Portability.

Product	Feature	N1 Mandatory Software Packages				N1 Add on Software Packages
		Management	Foundation	Advanced	Premium	
CloudEngine 9860 Series Switch						AI Fabric Function Package
	Basic software	√	√	√	√	
	IPV6	√	√	√	√	
	Lossless upgrade	√	√	√	√	
	Telemetry		√	√	√	
	LLETH					√
iMaster NCE-FabricInsight Analyzer	Basic network analysis functions of Telemetry		√	√	√	
	Network health ("1-3-5" intelligent O&M)			√	√	
	Value-added functions for network traffic analysis (managing 100 VMs)				√	
For details about product function differences, refer to the product documentation.						

Note: For detailed information of Huawei CloudFabric N1 business model, visit <https://e.huawei.com/en/material/networking/dcs/switch/03a0e69bfa2c4f168323ba94a75f1f09>.

Product Specifications

Note: This content is applicable only to regions outside mainland China. Huawei reserves the right to interpret this content.

Functions and Specification

Item	CloudEngine 9860-4C-EI
Device virtualization	M-LAG
Network convergence	DCBX, PFC and ETS
	RDMA and RoCE (RoCE v1 and RoCE v2)
Programmability	OPS
	Ansible-based automatic configuration and open-source module release
Traffic analysis	NetStream
	sFlow
VLAN	Adding access, trunk, and hybrid interfaces to VLANs
	Default VLAN
	GVRP
MAC address table	Dynamic learning and aging of MAC address entries
	Static, dynamic, and blackhole MAC address entries
	Packet filtering based on source MAC addresses
	MAC address limiting based on ports and VLANs
IP routing	IPv4 routing protocols, such as RIP, OSPF, IS-IS, and BGP
	IPv6 routing protocols, such as RIPng, OSPFv3, IS-ISv6, and BGP4+
IPv6	IPv6 Neighbor Discovery (ND)
	Path MTU Discovery (PMTU)
	TCP6, IPv6 ping, IPv6 tracert, IPv6 socket, UDP6, and raw IPv6
Multicast	Multicast routing protocols such as IGMP, PIM-SM, PIM-DM
	Fast leaving of multicast member interfaces
	Multicast traffic suppression
	Link Aggregation Control Protocol (LACP)
	STP, RSTP, VBST, and MSTP
	BPDU protection, root protection, and loop prevention
Reliability	Device Link Detection Protocol (DLDP)
	VRRP, VRRP load balancing, and BFD for VRRP
	BFD for BGP/IS-IS/OSPF/static route
	Traffic classification based on Layer 2 headers, Layer 3 protocols, Layer 4 protocols, and 802.1p priority
	ACL, CAR, re-marking, and scheduling

Item	CloudEngine 9860-4C-EI
QoS	Queue scheduling algorithms, including PQ, WRR, DRR, PQ+WRR, and PQ+DRR
	Congestion avoidance mechanisms, including WRED and tail drop
	Traffic shaping
Intelligent O&M	Network-wide path detection
	Telemetry
	In-band OAM (IOAM)
	AI ECN
	PFC Deadlock Prevention
	Console, Telnet, and SSH terminals
Intelligent and Lossless Network	Network management protocols, such as SNMPv1/v2/v3
	File upload and download through FTP and TFTP
Configuration and maintenance	BootROM upgrade and remote upgrade
	Hot patches
	User operation logs
	Zero Touch Provisioning (ZTP)
	Command line authority control based on user levels, preventing unauthorized users from using commands
	Defense against DoS address attacks, ARP storms, and ICMP attacks
	Port isolation, port security, and sticky MAC
Security and management	Binding of the IP address, MAC address, port number, and VLAN ID
	Authentication methods, including AAA, RADIUS, and HWTACACS
	Remote Network Monitoring (RMON)

Performance and Scalability

Item	CloudEngine 9860-4C-EI
Maximum number of MAC address entries	8K
Maximum number of routes (FIB IPv4/IPv6)	920K/520K
ARP table size	32K
Maximum number of VRFs	2048
IPv6 ND table size	32K
Maximum number of VRRP groups	256
Maximum number of ECMP paths	128
Maximum number of LAGs	1024
Maximum number of links in a LAG	144
Maximum number of MSTP instances	64

Item	CloudEngine 9860-4C-EI
Maximum number of VLANs where VBST can be configured	60

Note: This specification may vary between different scenarios. Please contact Huawei for details. ⁴

Hardware Specifications

Item	CloudEngine 9860-4C-EI	
Physical features	Dimensions (W x D x H)	442 mm x 765 mm x 175 mm
	Weight (excluding optical transceivers, power modules, and fan assemblies/including AC power modules and fan assemblies, excluding optical transceivers, kg)	26/46.2
	Switching capacity (Tbps)	25.6
	Forwarding performance (Mpps)	7600
Ports	4 slots Up to 32*400GE QSFP-DD ports or 128*100GE QSFP28 ports	
Card	Number of card slots	4
	Card type	Flexible card
	Card specification	CE98-D32CQ card: 32*100GE (QSFP28) CE98-D8DQ card: 8*400GE (QSFP-DD)
	Typical power consumption	CE98-D32CQ card: 242W CE98-D8DQ card: 198W
	Maximum power consumption	CE98-D32CQ card: 284W CE98-D8DQ card: 238W
Management interface	Out-of-band management port	1 x GE management interface
	Console port	1 x RJ45 interface
	USB port	1
CPU	Main frequency (GHz)	2.2
	Number of cores	4
Storage	DRAM	16 GB
	NOR flash	Two 32 MB flash memories
	SSD flash	64 GB
System	System buffer	65 MB
Power supply	Power modules	1200 W AC
	Power module backup	2+2 backup
	Rated voltage range (V)	AC: 100 V to 240 V HVDC: 240 V DC
	Maximum voltage range (V)	AC: 90 V to 290 V

Item	CloudEngine 9860-4C-EI	
		HVDC: 190 V to 290V
	Rated input current	1200 W AC&240 V DC power module : 10 A (100 V AC to 130 V AC)/8 A (200 V AC to 240 V AC)/8 A (240 V DC)
	Typical power consumption	Fully configured with four CE98-D32CQ cards: 1231 W (50% throughput, short-distance QSFP28 optical modules on 64 ports and long-distance QSFP28 optical modules on another 64 ports, two power modules) Configured with four CE98-D8DQ cards: 1289 W (50% throughput, short-distance QSFPDD optical modules on 32 ports, two power modules)
	Maximum power consumption	Configured with four CE98-D32CQ cards: 1627 W (70% of the full fan speed at an ambient temperature of 40°C) Configured with four CE98-D8DQ cards: 1717 W (full fan speed at an ambient temperature of 40°C)
	Frequency (AC, Hz)	50/60
Heat dissipation	Heat dissipation mode	Air cooling
	Number of fan trays	5
	Heat dissipation airflow	Back-to-front airflow
	Maximum heat consumption (BTU/hour)	Configured with four CE98-D32CQ cards: 5553 BTU/hour (70% of the full fan speed at an ambient temperature of 40°C) Configured with four CE98-D8DQ cards: 5861 BTU/hour (full fan speed at an ambient temperature of 40°C)
Environment specifications	Long-term operating temperature (°C)	0°C to 40°C (0-1800 m) The temperature decreases by 1°C each time the altitude increases by 220 m.
	Storage temperature (°C)	-40°C to +70°C
	Relative humidity	5% to 95%
	Operating altitude (m)	Up to 5000
	Noise (sound pressure, 27°C)	Back-to-front airflow: < 66 dBA
	Surge protection	PAC1K2S12-B series power module: <ul style="list-style-type: none"> AC: 4 kV in common mode and 2.5 kV in differential mode DC: 4 kV in common mode and 2 kV in differential mode PAC1K2S12-CB series power module: <ul style="list-style-type: none"> AC: 6 kV in common mode and 6 kV in differential mode DC: 4 kV in common mode and 2 kV in differential mode
Reliability	MTBF (year)	21.91
	MTTR (hour)	3.43
	Availability	0.9999934738

Note: For detailed information of CloudEngine 9800 hardware information, visit <https://support.huawei.com/enterprise/en/doc/EDOC1000019246?idPath=7919710%7C21782165%7C21782239%7C22318540%7C7597815>.

Safety and Regulatory Compliance

The following table lists the safety and regulatory compliance of CloudEngine switches.

Certification Category	Description
Safety	<ul style="list-style-type: none"> • EN 60950-1 • EN 60825-1 • EN 60825-2 • UL 60950-1 • CSA-C22.2 No. 60950-1 • IEC 60950-1 • AS/NZS 60950-1 • GB4943
Electromagnetic Compatibility (EMC)	<ul style="list-style-type: none"> • EN 300386 • EN 55032: CLASS A • EN 55024 • IEC/EN 61000-3-2 • IEC/EN 61000-3-3 • FCC 47CFR Part15 CLASS A • ICES-003: CLASS A • CISPR 32: CLASS A • CISPR 24 • AS/NZS CISPR32 • VCCI- CISPR32: CLASS A • GB9254 CLASS A
Environment	<ul style="list-style-type: none"> • 2011/65/EU EN 50581 • 2012/19/EU EN 50419 • (EC) No.1907/2006 • GB/T 26572 • ETSI EN 300 019-1-1 • ETSI EN 300 019-1-2 • ETSI EN 300 019-1-3 • ETSI EN 300 753 GR63

Note

EMC: electromagnetic compatibility

CISPR: International Special Committee on Radio Interference

EN: European Standard

ETSI: European Telecommunications Standards Institute

CFR: Code of Federal Regulations

FCC: Federal Communication Commission

IEC: International Electrotechnical Commission

AS/NZS: Australian/New Zealand Standard

VCCI: Voluntary Control Council for Interference

UL: Underwriters Laboratories

CSA: Canadian Standards Association

Supported MIBs

For details about the MIB information, visit

<https://support.huawei.com/hedex/hdx.do?docid=EDOC1100101219&lang=en&idPath=24030814%7C21782165%7C21782239%7C22318540%7C7597815>.

Optical Transceivers and Cable

For details about the optical transceivers and cables information, visit

<https://e.huawei.com/en/material/networking/dswitch/f6d91cf16df0474998087676a33fd41e>.

Ordering Information

Mainframe	
CE9860-4C-EI-B	CE9860-4C-EI mainframe (4*subcard slots, 4*AC power modules, 5*fan modules, port-side intake)
CE9860-4C-EI	CE9860-4C-EI mainframe (4*subcard slots, without fan and power modules)

Subcard	
CE98-D32CQ	CE9860:32 Port 100GE QSFP28 Interface Card
CE98-D8DQ	CE98:8 Port 400GE QSFP-DD Interface Card

Fan box		
Model	Description	Applicable Product
FAN-180C-B	Fan box(B,FAN panel side exhaust)	CE9860-4C-EI

Power		
Model	Description	Applicable Product
PAC1K2S12-C	1200W AC&240V DC Power Module (Back to Front,Power panel side air-out)	CE9860-4C-EI

Software	
N1-CE98LIC-CFFD	N1-CloudFabric Foundation SW License for CloudEngine 9800
N1-CE98CFFD- SnS1Y	N1-CloudFabric Foundation SW License for CloudEngine 9800-SnS-1 Year
N1-CE98LIC-CFAD	N1-CloudFabric Advanced SW License for CloudEngine 9800

Software	
N1-CE98CFAD-SnS1Y	N1-CloudFabric Advanced SW License for CloudEngine 9800-SnS-1 Year
N1-CE98LIC-CFPM	N1-CloudFabric Premium SW License for CloudEngine 9800
N1-CE98CFPM-SnS1Y	N1-CloudFabric Premium SW License for CloudEngine 9800 -SnS-Year
N1-CE98LIC-AIF	N1-CloudEngine 9800 AI Fabric Function
N1-CE98AIF-SnS1Y	N1-CloudEngine 9800 AI Fabric Function-SnS-Year

Networking and Application

Data Center Applications

On a typical data center network, CloudEngine 16800/12800/9800 switches work as core switches, whereas CloudEngine 6800 and CloudEngine 5800 switches work as ToR switches and connect to the core switches using 100GE/40GE/10GE ports.

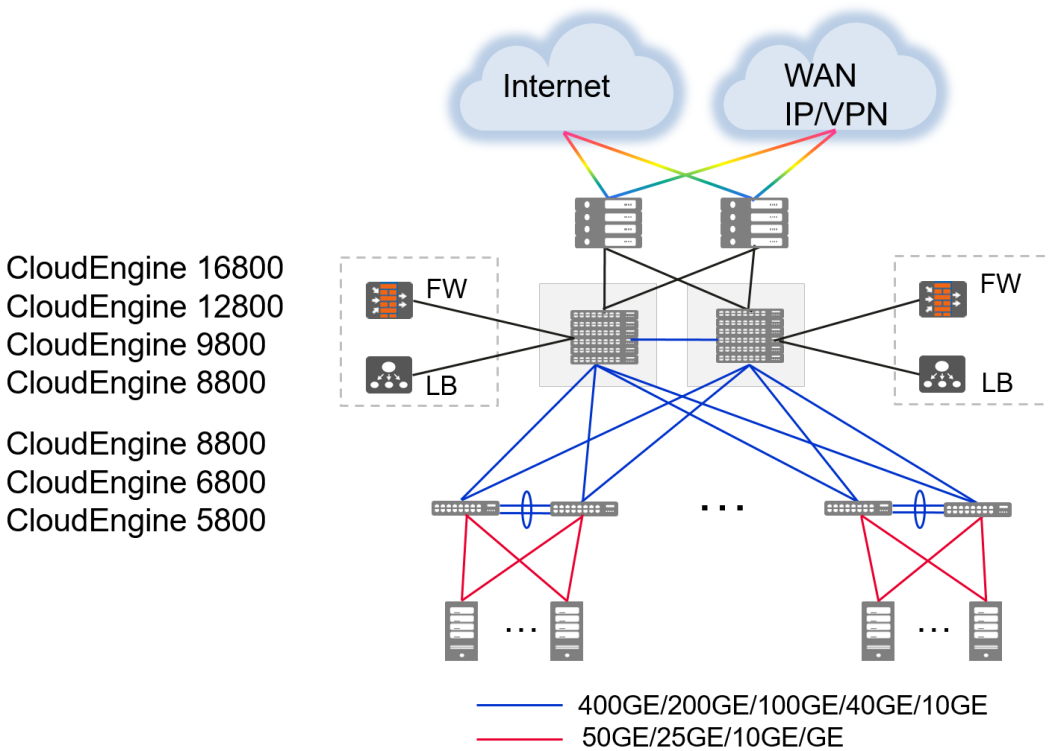

Copyright © Huawei Technologies Co., Ltd. 2021. All rights reserved.

No part of this document may be reproduced or transmitted in any form or by any means without prior written consent of Huawei Technologies Co., Ltd.

Trademarks and Permissions



HUAWEI and other Huawei trademarks are trademarks of Huawei Technologies Co., Ltd.

All other trademarks and trade names mentioned in this document are the property of their respective holders.

Notice

The purchased products, services and features are stipulated by the contract made between Huawei and the customer. All or part of the products, services and features described in this document may not be within the purchase scope or the usage scope. Unless otherwise specified in the contract, all statements, information, and recommendations in this document are provided "AS IS" without warranties, guarantees or representations of any kind, either express or implied.

The information in this document is subject to change without notice. Every effort has been made in the preparation of this document to ensure accuracy of the contents, but all statements, information, and recommendations in this document do not constitute a warranty of any kind, express or implied.

Huawei Technologies Co., Ltd.

Address: Huawei Industrial Base Bantian, Longgang Shenzhen 518129 People's Republic of China

Website: www.huawei.com