

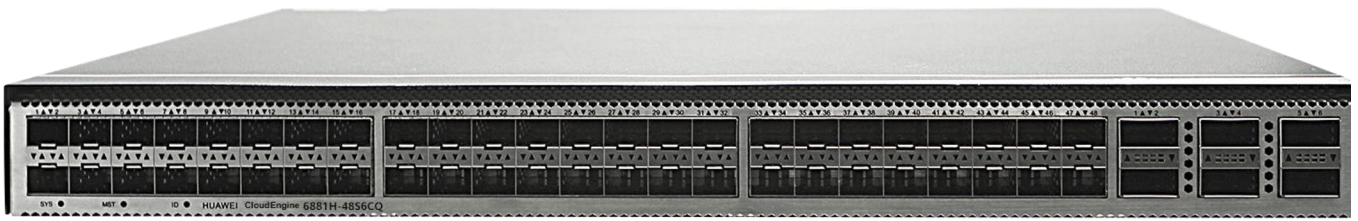

Huawei CloudEngine 6881H Switch Datasheet

Huawei CloudEngine 6881H series switches are next-generation 10GE access switches that provide high performance and high port density for data center networks (DCNs), using Huawei's YunShan platform.



www.huawei.com

Product Overview

Huawei CloudEngine 6881H series switches are next-generation 10GE access switches that provide high performance and high port density for DCNs. The CloudEngine 6881H series has an advanced hardware architecture with 40GE/100GE uplink ports and high-density 10GE access ports. Using Huawei's next-generation YunShan platform, CloudEngine 6881H series switches support extensive DC features and flexible selection of the airflow direction (front-to-back or back-to-front). The CloudEngine 6881H can work with CloudEngine 16800 series DC core switches to build elastic, virtual, and high-quality 40GE/100GE fully-connected networks, meeting requirements of DCs in the cloud era.

CloudEngine 6881H series switches provide high-density 10GE access to help enterprises and carriers build DCNs in the cloud computing era. They can also work as core or aggregation switches on campus networks.

Huawei CloudEngine 6800 series switches provide high-speed forwarding at line-rate on all ports in both Layer2 and Layer3 modes.

Product Appearance

CloudEngine 6881H-48S6CQ series switches provide 48 x 10GE SFP+ ports and 6 x 100GE QSFP28 ports.



CloudEngine 6881H-48T6CQ series switches provide 48 x 10GE BASE-T ports and 6 x 100GE QSFP28 ports.

CloudEngine 6881H series switches provide high-density 10GE access to help enterprises and carriers build DCNs in the cloud computing era. They can also work as core or aggregation switches on campus networks.



Product Characteristics

High-Density Access, Providing Superior Capacity

- The CloudEngine 6881H series provides up to 48 x 10GE ports, allowing for high-density 10GE server access and smooth evolution. It also allowing for line-speed processing for jumbo frames.
- The CloudEngine 6881H series provides up to 6 x 100GE QSFP28 ports. Each QSFP28 port can also be used as one 40GE QSFP+ port, enabling flexible networking. The uplink 40GE/100GE ports can be connected to CloudEngine 16800 series switches to build a nonblocking network platform.

Inter-Device Link Aggregation, Ensuring High Efficiency and Reliability

- CloudEngine 6881H series switches support M-LAG, which enables links of multiple switches to aggregate into one, improving link reliability from the card level to the device level.
- Switches in an M-LAG all work in active state to share traffic and back up each other, enhancing system reliability.
- Switches in an M-LAG can be upgraded independently. During the upgrade, other switches in the system take over traffic forwarding to ensure uninterrupted services.
- M-LAG supports dual-homing to Ethernet, VXLAN, and IP networks, allowing for flexible networking.

Virtualized Hardware Gateway, Enabling Quick Deployment

- CloudEngine 6881H series can work with mainstream virtualization platforms, functioning as a high-performance hardware VXLAN gateway on an overlay network and supporting up to 16 million tenants.
- When functioning as a hardware gateway on an overlay network, a CloudEngine 6881H switch can connect to cloud platforms through open APIs, facilitating unified management of virtual and physical networks.
- This enables fast service deployment without changing the customer network, protecting customers' network investment.
- CloudEngine 6881H series switches support Border Gateway Protocol - Ethernet VPN (BGP BGP-EVPN), which can run as the VXLAN control plane to simplify VXLAN configuration within and between DCs.

Open and Programmable Network, Enabling Flexible Customization

- The built-in open programmability system (OPS) module of CloudEngine 6881H series switches implements programmability on the control plane.
- The OPS provides open APIs for integration with mainstream cloud platforms (including commercial and open-source cloud platforms) and third-party controllers, enabling flexible service customization and automatic management.
- Users or third-party developers can use the open APIs to develop and deploy dedicated network management policies, implementing fast expansion of service functions, automatic service deployment, and intelligent device management. This ensures automatic operations and maintenance (O&M) and minimizes management costs.
- The CloudEngine 6881H series supports Ansible — an automatic management and O&M tool — to implement unified provisioning of physical and virtual networks.
- The OPS is dedicated to seamlessly integrate DC services and networks to provide service-oriented, software-defined networks.

ZTP, Implementing Automatic O&M

- The CloudEngine 6881H series supports Zero Touch Provisioning (ZTP). ZTP enables the CloudEngine 6881H series to automatically obtain and load version files from file server, freeing network engineers from onsite configuration and deployment. ZTP reduces labor costs and improves device deployment efficiency.
- ZTP provides built in scripts through open APIs. Data center personnel can use a programming language they are familiar with, such as Python, to centrally configure network devices.
- ZTP decouples the configuration time of new devices from the device quantity and area distribution, which improves service provisioning efficiency.

iMaster NCE-FabricInsight-based Intelligent O&M

The CloudEngine 6881H series provides telemetry technology to collect device data in real time and send the data to iMaster NCE-FabricInsight — Huawei's analyzer for DCNs. iMaster NCE -FabricInsight analyzes network data based on the intelligent fault identification algorithm, accurately displays the real-time network status, effectively demarcates and locates faults in a timely manner, and identifies network problems that affect user experience, accurately guaranteeing user experience.

iMaster NCE Fabric-based Simplified Network Deployment

The CloudEngine 6881H series can interconnect with iMaster NCE-Fabric through standard protocols such as NETCONF and SNMP to adapt to networks and implement automatic network management, providing more efficient and intelligent operation methods, simplifying network management, and reducing the OPEX.

Flexible Airflow Design, Improving Energy Efficiency

Flexible front-to-back or back-to-front airflow design

- The Cloud Engine 6881H series uses a strict front-to-back or back-to-front airflow design that isolates cold air channels from hot air channels. This design improves heat dissipation efficiency and meets design requirements of DC equipment rooms.
- Air can flow from front to back or back to front depending on the fans and power modules that are used.
- Redundant power modules and fans can be configured to ensure service continuity.

Innovative energy-saving technologies

The CloudEngine 6881H series uses energy-saving chips and an intelligent fan speed control scheme to measure system power consumption in real time. These energy-saving technologies reduce O&M costs and contribute to a greener DC.

Clear Indicators, Simplifying Maintenance

Clear indicators

- Port indicators clearly show the port status and port rate. The 100GE port indicators can show the states of all ports derived from the 100GE ports.
- State and stack indicators on both the front and rear panels enable users to maintain the switch from either side.
- The CloudEngine 6881H series supports remote positioning. Users can turn on the remote positioning indicator through the NMS or console to easily identify the switches they want to maintain in an equipment room full of devices.

Simple maintenance

- The management port, fans, and power modules are on the front panel, which facilitates device maintenance.
- Data ports are located at the rear, facing servers. This simplifies cabling.

Licensing

CloudEngine 6881H series switches support Huawei IDN One Software (N1) business model, which bundles iMaster NCE-Fabric, iMaster NCE-FabricInsight, and CloudEngine switches in typical scenarios to simplify transactions. This provides customers with more functions and value, and protects customers' software investment through Software License Portability.

Feature	N1 Software Package (Mandatory)			N1 Add-On Package (Optional)			
	Foundation	Advanced	Premium	TCP Acceleration Value-added Package	Multi-Cloud and Multi-DC Scenario Package	Value-added Package of Network Traffic Analysis	Digital Map
Basic functions (including IPv6 and VXLAN)	•	•	•				
Telemetry	•	•	•				
PTP	•	•	•				
TCP optimization				•			
Automation	•	•	•				
Basic intent functions			•				
Runbook		•	•				
Multi-cloud and multi-DC automation scenario package					•		
Basic digital map functions							•
Basic network analysis functions	•	•	•				
Network health evaluation		•	•				
Value-added functions of network traffic analysis (100 VMs)			•				
Value-added functions of network traffic analysis (1000 VMs)						•	
Value-added package of multi-cloud and multi-DC analysis scenarios					•		
Configuration	Select one from the three packages. The Advanced package contains features of the Foundation package, and the Premium package contains the features of the Advanced package.			Used together with the Foundation, Advanced, or Premium package.			

For detailed information of the Huawei CloudFabric N1 business model, visit:

<https://e.huawei.com/en/material/networking/dcs/switch/03a0e69bfa2c4f168323ba94a75f1f09>

Product Specifications

Item	CloudEngine 6881H-48S6CQ	CloudEngine 6881H-48T6CQ
Device virtualization	M-LAG	
Network virtualization	VXLAN routing and VXLAN bridging	
	BGP-EVPN	
	QinQ access VXLAN	
SDN	iMaster NCE-Fabric	
Programmability	OpenFlow	
	OPS programming	
	Ansible-based automatic configuration and open-source module release	
Traffic analysis	NetStream	
VLAN	Access, trunk, and hybrid ports	
	Default VLAN	
	QinQ	
MAC address table	Automatic MAC address learning and aging	
	Static, dynamic, and blackhole MAC address entries	
	Source MAC address filtering	
	MAC address learning limiting based on ports and VLANs	
IP routing	IPv4 dynamic routing protocols such as RIP, OSPF, IS-IS, and BGP	
	Static routes	
	Routing policy	
	IPv6 dynamic routing protocols such as RIPng, OSPFv3, IS-ISv6, and BGP4+	
	IP packet fragmentation and reassembly ¹	
IPv6	VXLAN over IPv6	
	IPv6 VXLAN over IPv4	
	IPv6 neighbor discovery (ND)	

Path MTU Discovery (PMTU)
TCP6, IPv6 ping, IPv6 tracert, IPv6 socket, UDP6, and raw IPv6
ICMPv6 in accordance with RFC 4443 and RFC 4884 and RFC 8335

Item	CloudEngine 6881H-48S6CQ	CloudEngine 6881H-48T6CQ
Multicast	Multicast routing protocols such as IGMP, and PIM-SM	
	IGMP snooping	
	IGMP snooping proxy	
	Fast leaving of multicast member interfaces	
	Multicast traffic suppression	
Reliability	Link Aggregation Control Protocol (LACP)	
	STP, RSTP, VBST, and MSTP	
	BPDU protection	
	Smart link and multi-instance	
	Hardware-based Bidirectional Forwarding Detection (BFD), with a minimum packet sending interval of 3.3 ms	
	VRRP, VRRP load sharing, and BFD for VRRP	
	BFD for BGP, IS-IS, OSPF, and static routes	
	BFD for VXLAN	
QoS	Traffic classification based on Layer 2 headers, Layer 3 headers, and Layer 4 protocol priorities.	
	ACL, CAR, re-marking, and scheduling	
	Queue scheduling modes such as PQ, DRR, and PQ+DRR	
	Congestion avoidance mechanisms, including WRED and tail drop	
	Traffic shaping	
O&M	Packet Conservation Algorithm for Internet (iPCA)	
	Network-wide path detection	
	Telemetry	

	Enhanced ERSPAN
	VXLAN OAM: VXLAN ping and VXLAN tracet
Configuration and maintenance	Console, Telnet, and SSH terminals
	Network management protocols, such as SNMPv1/v2/v3
	File upload and download through FTP and TFTP
	Bootrom-based upgrade and remote online upgrade
	Hot patches
	User operation logs
	Configuration rollback
	ZTP
Security and management	802.1X authentication
	Command line authority control based on user levels, preventing unauthorized users from using commands
	Defense against DoS, ARP, and ICMP attacks
	Port isolation, port security, and sticky MAC
	Binding of the IP address, MAC address, port number, and VLAN ID
	Authentication methods, including AAA, RADIUS, and HWTACACS
	Remote network monitoring (RMON)

1. Packets whose length exceeds the MTU on the forwarding plane are fragmented before forwarding.

Performance and Scalability

Item	CloudEngine 6881H-48S6CQ/ CloudEngine 6881H-48T6CQ
Maximum number of MAC address entries	256K
Maximum number of routes (FIB IPv4/IPv6)	256K/80K
ARP size	256K
Maximum number of VRFs	4096
IPv6 ND table size	80K

Maximum number of multicast routes (multicast FIB IPv4/IPv6)	32K/2K
Maximum number of VRRP groups	1024
Maximum number of ECMP paths	128
Maximum ACL Number	15K
Maximum number of VXLAN bridge domains	8K
Maximum number of BDIF interfaces	8K
Maximum number of virtual tunnel endpoints (VTEPs)	5K
Maximum number of LAGs	1024
Maximum number of links in a LAG	256
Maximum number of MSTP instance	64
Maximum number of VLANs where VBST can be configured	1000
Maximum number of BGP neighbors	1024
Maximum number of VXLAN tunnels	5000

Hardware Specifications

Item		CloudEngine 6881H-48S6CQ	CloudEngine 6881H-48T6CQ
Physical Features	Dimensions (W × D ×H, mm)	442*420*43.6	
	Weight without packaging (full configuration) (kg)	7.8	8.9
	Switching capacity (Tbps)	2.16	
	Forwarding performance (Mpps)	954	
10GE SFP+ ports		48	0

10GE BASE-T ports		0	48
40/100GE QSFP28 ports		6	
Management interface	Out-of-band management port	1*GE management interface	
	Console port	1*RJ45 interface	
	USB port	1	
CPU	Main frequency (HZ)	1.4G	
	Number of cores	4	
Storage	RAM	4GB	
	NOR Flash	64MB	
	NAND Flash	4GB	
System	System buffer	42MB	
Power Supply System	Power modules	600W AC 1000W -48V DC 1200W 380V HVDC	
	Rated voltage range (V)	AC: 100V to 240V DC: -48V to -60V HVDC: 240V to 380V	
	Maximum voltage range (V)	AC: 90V to 290V DC: -38.4V to -72V HVDC: 190V to 400V	
	Maximum input current	AC 600W: 100V to 240V 8 A 1000W -48V DC: -48 to 60V 30A 1200W 380V HVDC: 190V 8A	

Item	CloudEngine 6881H-48S6CQ	CloudEngine 6881H-48T6CQ
-------------	---------------------------------	---------------------------------

	Typical power	194W (100% traffic load, copper cable, normal temperature, dual power modules) 240W (100% traffic load, short-distance optical transceivers, normal temperature, dual power modules)	347 W (100% traffic load, 3 m network cables and copper cables, normal temperature, dual power modules) 362 W (100% traffic load, 3 m network cables and shortdistance optical modules, normal temperature, dual power modules)	
	Maximum power	349W	452W	
	Frequency (AC, HZ)	50/60	50/60	
Heat Dissipation	Heat dissipation mode	Air cooling		
	Number of fan trays	4		
	Heat dissipation airflow	Front-to-back or back-to-front airflow		
Environment specifications	Long-term operating temperature (°C)	0°C to 40°C (0-1800m) The temperature decreases by 1°C each time the altitude increases by 220 m.		
	Storage temperature (°C)	-40°C to +70°C		
	Relative humidity	5% to 95%		
	Operating altitude (m)	Up to 5000		
	Sound power at 27°C (dBA)	Front-to-back airflow:	< 58	Front-to-back airflow: < 49
		Back-to-front airflow:	< 57	Back-to-front airflow: < 50
Sound power at 40°C (dBA)	Front-to-back airflow:	< 75	Front-to-back airflow: < 69	
	Back-to-front airflow:	< 74	Back-to-front airflow: < 67	

	Surge protection	AC power supply protection: 6 kV in common mode and 6 kV in differential mode DC power supply protection: 4 kV in common mode and 2 kV in differential mode	
Item		CloudEngine 6881H-48S6CQ	CloudEngine 6881H-48T6CQ
Reliability	MTBF (year)	45.90	48.16
	MTTR (hour)	1.57	1.78
	Availability	0.9999960856	0.9999953209

Ordering Information

Mainframe		
CE6881H-48S6CQ-B	CE6881H-48S6CQ-B switch (48*10G SFP+, 6*100G QSFP28, 2*AC power modules, 4*fan modules, port-side intake)	
CE6881H-48S6CQ-F	CE6881H-48S6CQ-F switch (48*10G SFP+, 6*100G QSFP28, 2*AC power modules, 4*fan modules, port-side exhaust)	
CE6881H-48S6CQ	CE6881H-48S6CQ switch (48*10G SFP+, 6*100G QSFP28, without fan and power modules)	
CE6881H-48T6CQ-B	CE6881H-48T6CQ switch (48*10GE RJ45, 6*100GE QSFP28, 2*AC power modules, 4*fan modules, port-side intake)	
CE6881H-48T6CQ-F	CE6881H-48T6CQ switch (48*10GE RJ45, 6*100GE QSFP28, 2*AC power modules, 4*fan modules, port-side exhaust)	
CE6881H-48T6CQ	CE6881H-48T6CQ switch (48*10GE RJ45, 6*100GE QSFP28, without fan and power modules)	
Fan Box		
Model	Description	Applicable Product
FAN-031A-F	Fan box (F,FAN panel side intake)	CloudEngine 6881H series products
FAN-031A-B	Fan box (B,FAN panel side exhaust)	CloudEngine 6881H series products
Power		
Model	Description	Applicable Product
PAC600S12-EF	600W AC Power Module(Front to Back,Power panel side intake)	CloudEngine 6881H series products
PAC600S12-EB	600W AC Power Module(Back to Front, Power panel side exhaust)	CloudEngine 6881H series products
PDC1000S12-DF	1000W DC Power Module (Front to Back,Power panel side intake)	CloudEngine 6881H series products
PDC1000S12-DB	1000W DC Power Module (Back to Front,Power panel side exhaust)	CloudEngine 6881H series products

PHD1K2S12-DB	1200W HVDC Power Module (Back to Front, Power panel side exhaust)	CloudEngine 6881H series products
Software		
N1-CE68LIC-CFFD	N1-CloudFabric Foundation SW License for CloudEngine 6800	
N1-CE68CFFD-SnS1Y	N1-CloudFabric Foundation SW License for CloudEngine 6800-SnS-Year	
N1-CE68LIC-CFAD	N1-CloudFabric Advanced SW License for CloudEngine 6800	
N1-CE68CFAD-SnS1Y	N1-CloudFabric Advanced SW License for CloudEngine 6800-SnS-Year	
Mainframe		
N1-CE68LIC-CFPM	N1-CloudFabric Premium SW License for CloudEngine 6800	
N1-CE68CFPM-SnS1Y	N1-CloudFabric Premium SW License for CloudEngine 6800 -SnS-Year	
N1-CE-F-LIC-MDCA	N1-CloudEngine Data Center Switch Multi-cloud Multi-DC Value-added Package - Fixed	
N1-CEFMDCA -SnS1Y	N1-CloudEngine Data Center Switch Multi-cloud Multi-DC Value-added Package, Per Fixed device -SnS-Year	
N1-CE68LIC-TCPAC	N1-CloudEngine 6800 Value-added Package for the TCP Acceleration Scenarios	
N1-CE68TCPAC-SnS1Y	N1-CloudEngine 6800 Value-added Package for the TCP Acceleration Scenarios-Subscription and Support-Year	
N1-CE-F-LIC-DM	N1-CloudEngine Digital Map Basic Function-Fixed	
N1-CEFDM-SnS1Y	N1-CloudEngine Digital Map Function, Per Fixed device-SnS-Year	
N1-CE-F-LIC-AFP1KVM	N1-CloudEngine Network Intelligent Analysis Flow Advantage Per 1000 VM	
N1-CEFAFP1KVM-SnS1Y	N1-CloudEngine Network Intelligent Analysis Flow Advantage Per 1000 VM, Per Fixed device-SnS-Year,Electronic	
N1-CE68UPG-F-A	N1-CloudEngine 6800 Upgrade SW License:Foundation to Advanced	
N1-CE68UGFA-SnS1Y	N1-CloudEngine 6800 Upgrade SW License:Foundation to Advanced-Subscription and Support-Year	
N1-CE68UPG-A-P	N1-CloudEngine 6800 Upgrade SW License:Advanced to Premium	
N1-CE68UGAP-SnS1Y	N1-CloudEngine 6800 Upgrade SW License:Advanced to Premium-Subscription and Support-Year	

Applications in the Networking

Application in a DC

On a typical DCN, CloudEngine 16800 or 8800 switches function as core switches, whereas CloudEngine 6881H switches function as TOR switches and connect to the core switches through 40GE/100GE ports, building an end-to-end 100GE full-mesh network. The switches use VXLAN and other fabric protocols to establish a non-blocking large Layer 2 network, which allows large-scale VM migrations and flexible service deployments.

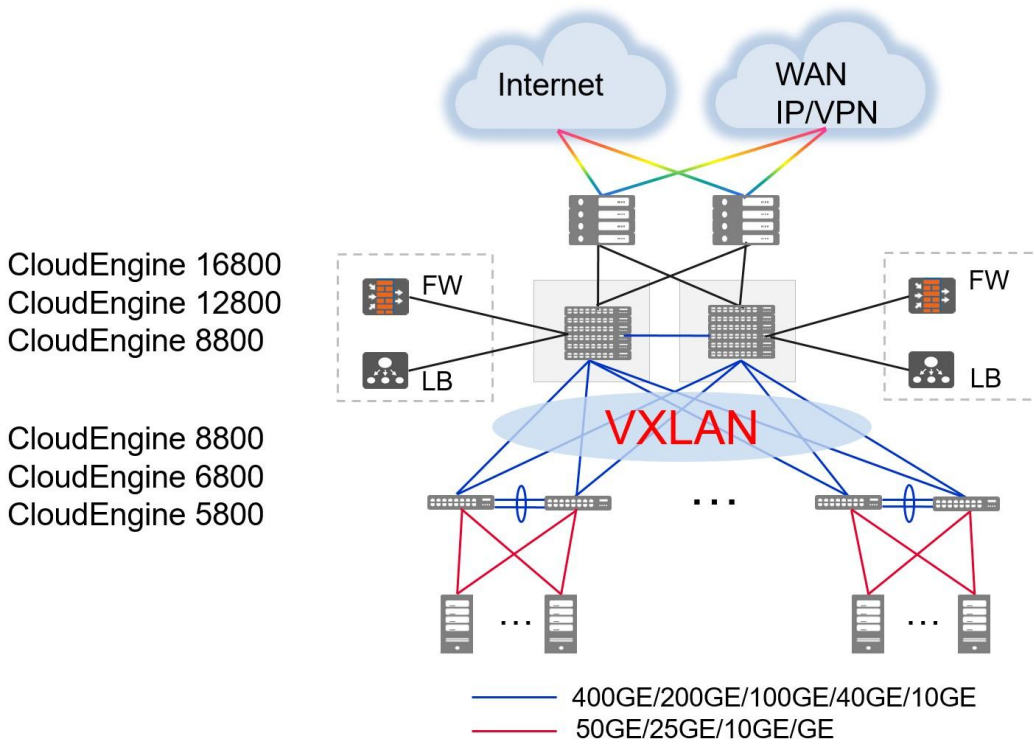

Note: VXLAN can also be used on campus networks to support flexible service deployment in different service areas.

Copyright © Huawei Technologies Co., Ltd. 2025. All rights reserved.

No part of this document may be reproduced or transmitted in any form or by any means without prior written consent of Huawei Technologies Co., Ltd.

Trademarks and Permissions



HUAWEI and other Huawei trademarks are trademarks of Huawei Technologies Co., Ltd.

All other trademarks and trade names mentioned in this document are the property of their respective holders.

Notice

The purchased products, services and features are stipulated by the contract made between Huawei and the customer. All or part of the products, services and features described in this document may not be within the purchase scope or the usage scope. Unless otherwise specified in the contract, all statements, information, and recommendations in this document are provided "AS IS" without warranties, guarantees or representations of any kind, either express or implied.

The information in this document is subject to change without notice. Every effort has been made in the preparation of this document to ensure accuracy of the contents, but all statements, information, and recommendations in this document do not constitute a warranty of any kind, express or implied.

Huawei Technologies Co., Ltd.

Address: Huawei Industrial Base, Bantian, Longgang, Shenzhen 518129, People's Republic of

China Website: www.huawei.com