



# Huawei CloudEngine 6857E-48T6CQ Switch Datasheet

Huawei CloudEngine 6857E series switches have advanced hardware architecture with 40GE/100GE uplink ports and high-density 10GE access ports.

CloudEngine 6857E series provide high-density 10GE access to help enterprises and carriers build a scalable data center network platform in the cloud computing era. They can also be used as aggregation or core switches for enterprise campus networks.

# Product Overview

Huawei CloudEngine 6857E series switches are next-generation 10GE Ethernet switches designed for data centers and high-end campus networks, providing high-performance, high-density 10GE ports, and low latency. The CloudEngine 6857E series uses an advanced hardware architecture with 100GE uplink ports and high density 10GE access ports.

Using the Huawei VRP8 software platform, CloudEngine 6857E series provide extensive data center service features and high stacking capability. In addition, the airflow direction (front-to-back or back-to-front) can be changed.

CloudEngine 6857E series can work with CloudEngine 16800 or CloudEngine 12800 switches to build an elastic, virtualized, high-quality fabric that meets the requirements of cloud-computing data centers.

CloudEngine 6857E series provide high-density 10GE access to help enterprises and carriers build a scalable data center network platform in the cloud computing era. They can also be used as aggregation or core switches for enterprise campus networks.

## Product Appearance

CloudEngine 6857E-48T6CQ switches provide 48 x 10GE Base-T ports, 6 x 100GE QSFP28 ports or 6 x 40GE QSFP+ ports.



## Product Characteristics

### High-Density 10GE Access

- CloudEngine 6857E series provide 48 x 10GE ports, high-density 10GE ports among 1 U ToR switches, allowing for high-density 10GE server access.
- CloudEngine 6857E series have a maximum of six 100GE QSFP 28 or 40GE QSFP+ ports. Each QSFP28 or QSFP+ port can be used as four 10GE SFP+ ports, providing flexibility in networking. The uplink QSFP28 or 40GE QSFP+ ports can be connected to CloudEngine 16800 or CloudEngine 12800 switches to build a non-blocking network platform.

### Inter-device Link Aggregation, High Efficiency and Reliability

- CloudEngine 6857E series support multichassis link aggregation group (M-LAG), which enables links of multiple switches to aggregate into one to implement device-level link backup.
- Switches in an M-LAG system all work in active state to share traffic and back up each other, enhancing system reliability.
- Switches in an M-LAG system can be upgraded independently. During the upgrade, other switches in the system take over traffic forwarding to ensure uninterrupted services.
- M-LAG supports dual-homing to Ethernet, VXLAN, and IP networks, allowing for flexible networking.
- With comprehensive inter-device link aggregation technology, the device networking coupling relationship evolves from stacking at the control plane to the use of M-LAG and then finally to coupling-free M-LAG Lite. This achieves active-active server access and zero interruption of services when upgrading switches.

### Virtualized Hardware Gateway, Enabling Quick Deployment

- CloudEngine 6857E series can work with the industry's mainstream virtualization platforms and acts a hardware gateway on an overlay network (VXLAN). The virtualization function protects investments by ensuring services can be deployed quickly without requiring network changes.
- CloudEngine 6857E series can connect to a cloud platform through open APIs, facilitating the unified management of virtual and physical networks.

- The hardware gateway deployment enables fast service deployment without changing the customer network, providing investment protection.
- CloudEngine 6857E series support Border Gateway Protocol - Ethernet VPN (BGP-EVPN), which can run as the VXLAN control plane to simplify VXLAN configuration within and between data centers.

## Standard Interfaces, Enabling Openness and Interoperability

- CloudEngine 6857E series support NETCONF and can work with Huawei iMaster NCE-Fabric.
- CloudEngine 6857E series support Ansible-based automatic configuration and open-source module release, expanding network functions and simplifying device management and maintenance.
- CloudEngine 6857E series can be integrated into mainstream SDN and cloud computing platforms flexibly and quickly.

## ZTP, Implementing Automatic O&M

- CloudEngine 6857E series support Zero Touch Provisioning (ZTP). ZTP enables the CloudEngine 6857E series to automatically obtain and load version files from a USB flash drive or file server, freeing network engineers from onsite configuration and deployment. ZTP reduces labor costs and improves device deployment efficiency.
- ZTP provides built-in scripts through open APIs. Data center personnel can use a programming language they are familiar with, such as Python, to centrally configure network devices.
- ZTP decouples the configuration time of new devices from the device quantity and area distribution, which improves service provisioning efficiency.

## FabricInsight-based Intelligent O&M

- The CloudEngine 6857E provides telemetry technology to collect device data in real time and send the data to Huawei data center network analyzer iMaster NCE-FabricInsight. The iMaster NCE-FabricInsight analyzes network data based on the intelligent fault identification algorithm, accurately displays the real-time network status, effectively demarcates and locates faults in a timely manner, and identifies network problems that affect user experience, accurately guaranteeing user experience.

## iMaster NCE-based Simplified Network Deployment

- CloudEngine 6857E series switches can interconnect with iMaster NCE-Fabric through standard protocols such as NetConf and SNMP to implement network automatic management and control, providing more efficient and intelligent operation methods, simplifying network management, and reducing the OPEX.

## Flexible Airflow Design, Improving Energy Efficiency

Flexible front-to-back/back-to-front airflow design

- CloudEngine 6857E series use a strict front-to-back/back-to-front airflow design that isolates cold air channels from hot air channels. This design improves heat dissipation efficiency and meets design requirements of data center equipment rooms.
- Air can flow from front to back or back to front depending on the fans and power modules that are used.
- Redundant power modules and fans can be configured to ensure service continuity.

Innovative energy-saving technologies

- CloudEngine 6857E series have innovative energy-saving chips and can measure system power consumption in real time. The fan speed can be adjusted dynamically based on system consumption. These energy-saving technologies reduce O&M costs and contribute to a greener data center.

## Clear Indicators, Simplifying Maintenance

Clear indicators

- Port indicators clearly show the port status and port rate. The 40GE/100GE port indicators can show the states of all ports derived from the 40GE/100GE ports.
- State and stack indicators on both the front and rear panels enable users to maintain the switch from either side.
- CloudEngine 6857E series support remote positioning. Remote positioning indicators enable users to easily identify the switches they want to maintain in an equipment room full of devices.

Simple maintenance

- The management port, fans, and power modules are on the front panel, which facilitates device maintenance.
- Data ports are located at the rear, facing servers. This simplifies cabling.

## Licensing

CloudEngine 6857E supports both the traditional feature based licensing mode and the latest Huawei IDN One Software (N1 Huawei IDN One Software (N1 mode for short) licensing mode. The CloudFabric N1 business model combines the NCE controller, analyzer, and CloudEngine switch software for use in a range of common scenarios. This simplifies transactions, provides customers with more functions and value, and protects their software investment with Software License Portability.

Product	Feature	N1 Mandatory Software Packages			N1 Add-on Software Packages
CloudEngine 6857E Series Switch		Foundation	Advanced	Premium	Multi-cloud Multi-DC Value-added Package
	Basic software	√	√	√	
	IPV6	√	√	√	
	VXLAN	√	√	√	
	Telemetry	√	√	√	
	MPLS		√	√	
iMaster NCE-Fabric Controller	SDN automation	√	√	√	
	Basic intent functions (simulation and verification, and network-wide configuration rollback)			√	
	Multi-cloud mMulti-DC function				√
iMaster NCE-FabricInsight Analyzer	Basic network analysis functions of telemetry	√	√	√	
	Network health ("1-3-5" intelligent O&M)		√	√	
	Value-added functions for network traffic analysis (managing 100 VMs)			√	
Version Mapping		Select one from three options. The Advanced software package contains functions from the Foundation software package. The Premium software package contains functions from the Advanced software package.			It is used with the Foundation, Advanced, or Premium software package.
For details about product function differences, refer to the product documentation.					

Note: For detailed information of Huawei CloudFabric N1 Business Model, visit <https://e.huawei.com/en/material/networking/dcs/switch/03a0e69bfa2c4f168323ba94a75f1f09>

# Product Specifications

Note: This content is applicable only to regions outside mainland China. Huawei reserves the right to interpret this content.

## Functions and Features

Item	CloudEngine 6857E-48T6CQ
Device virtualization	iStack
	M-LAG
Network virtualization	VXLAN routing and bridging
	BGP-EVPN
	QinQ access VXLAN
Data center interconnect	VXLAN mapping, implementing interconnection between multiple DCI networks at Layer 2
SDN	iMaster NCE-Fabric
Network convergence	DCBX, PFC, ETS
	RDMA and RoCE (RoCE v1 and RoCE v2)
Programmability	OPS
	Ansible-based automatic configuration and open-source module release
Traffic analysis	NetStream
	sFlow
VLAN	Adding access, trunk, and hybrid interfaces to VLANs
	Default VLAN
	QinQ
	MUX VLAN
	GVRP
MAC address table	Dynamic learning and aging of MAC address entries
	Static, dynamic, and blackhole MAC address entries
	Packet filtering based on source MAC addresses
	MAC address limiting based on ports and VLANs
IP routing	IPv4 routing protocols, such as RIP, OSPF, IS-IS, and BGP
	IPv6 routing protocols, such as RIPng, OSPFv3, IS-ISv6, and BGP4+
IPv6	IPv6 Neighbor Discovery (ND)
	Path MTU Discovery (PMTU)
	TCP6, IPv6 ping, IPv6 tracer, IPv6 socket, UDP6, and Raw IP6
Multicast	Multicast routing protocols such as IGMP, PIM-SM, PIM-DM, MSDP, and MBGP
	IGMP snooping
	IGMP proxy

Item	CloudEngine 6857E-48T6CQ
	Fast leaving of multicast member interfaces
	Multicast traffic suppression
	Multicast VLAN
Reliability	Link Aggregation Control Protocol (LACP)
	STP, RSTP, VBST, and MSTP
	BPDU protection, root protection, and loop protection
	Smart Link and multi-instance
	Device Link Detection Protocol (DLDP)
	ERPS (G.8032)
	Hardware-based Bidirectional Forwarding Detection (BFD)
	VRRP, VRRP load balancing, and BFD for VRRP
	BFD for BGP/IS-IS/OSPF/Static route
	BFD for VXLAN
QoS	Traffic classification based on Layer 2, Layer 3, Layer 4, and priority information
	ACL, CAR, re-marking, and scheduling
	Queue scheduling algorithms, including PQ, WRR, DRR, PQ+WRR, and PQ+DRR
	Congestion avoidance mechanisms, including WRED and tail drop
	Traffic shaping
O&M	Network-wide path detection
	Telemetry
	Statistics on the buffer microburst status
	VXLAN OAM: VXLAN ping and VXLAN tracet
Configuration and maintenance	Console, Telnet, and SSH terminals
	Network management protocols, such as SNMPv1/v2/v3
	File upload and download through FTP and TFTP
	BootROM upgrade and remote upgrade
	Hot patches
	User operation logs
	Zero Touch Provisioning (ZTP)
Security and management	Command line authority control based on user levels, preventing unauthorized users from using commands
	Defense against DoS address attacks, ARP storms, and ICMP attacks
	Port isolation, port security, and sticky MAC
	Binding of the IP address, MAC address, port number, and VLAN ID
	Authentication methods, including AAA, RADIUS, and HWTACACS

Item	CloudEngine 6857E-48T6CQ
	Remote Network Monitoring (RMON)

## Performance and Scalability

Item	CloudEngine 6857E-48T6CQ
Maximum number of MAC address entries	288K
Maximum number of Forwarding routes (FIB IPv4/ IPv6)	380K/256K
ARP table size	168K
Maximum number of VRF	4096
IPv6 ND (Neighbor Discovery) table size	64K
Maximum Number of multicast routes (Multicast FIB IPv4/IPv6)	8K/2K
Maximum VRRP groups	1K
Maximum number of ECMP paths	128
Maximum Number of broadcast domains	16K
Maximum number of BDIF	8K
Maximum number of tunnel endpoints (VTEP)	2K
Maximum number of lag group	1024/512/256/128/64
Maximum number of links in a lag group	2/4/8/16/32
Maximum number of MSTP instance	64
VBST (Maximum number of VLANs where VBST can be configured)	500

Note: This specification may vary between different scenarios. Please contact Huawei for details.

## Hardware Specifications

Item	CloudEngine 6857E-48T6CQ	
Physical Features	Dimensions (W x D xH, mm)	442*420*43.6
	Weight (excluding optical transceivers, power modules, and fan assemblies/ including AC power modules and fan assemblies, excluding optical transceivers, kg)	5.75/8.05
	Switching capacity (Tbps)	2.16
	Forwarding performance	1000

Item		CloudEngine 6857E-48T6CQ
	(Mpps)	
10GE SFP+ ports		0
10GE BASE-T		48
40/100GE QSFP28 ports		6
Management interface	Out-of-band management port	1*GE management interface
	Console port	1*RJ45
	USB port	1
CPU	Main frequency (GHZ)	1.6
	Number of cores	4
Storage	RAM	4GB
	NOR Flash	128MB
	NAND Flash	8GB
System	System buffer	32MB
Power Supply System	Power modules	AC: 600W AC DC: 1000W -48V DC HVDC: 1200W 380V HVDC
	Rated voltage range (V)	AC: 100V to 240V DC: -48V to -60V HVDC: 240V DC to 380V DC
	Maximum voltage range (V)	AC: 90V to 290V DC: -38.4VV to -72V HVDC: 190V DC to 400V DC
	Maximum input current	600W AC power module: 100V to 240V 8A 1000W DC power module: -48V to -60V 30A 1200 W high-voltage DC power module: 240V to 380V 8 A
	Frequency (AC, HZ)	50/60
Heat Dissipation	Heat dissipation mode	Air cooling
	Number of fan trays	4
	Heat dissipation airflow	Front-to-back or back-to-front airflow
Environment specifications	Long-term operating temperature (°C)	0°C to 40°C (0-1800m) The temperature decreases by 1°C each time the altitude increases by 220 m.
	Storage temperature(°C)	-40°C to +70°C
	Relative humidity	5% to 95%

Item		CloudEngine 6857E-48T6CQ
	Operating altitude (m)	Up to 5000

Note: For detailed information of CloudEngine 6800 Platform hardware information, visit

<https://support.huawei.com/enterprise/en/doc/EDOC1000019246?idPath=7919710%7C21782165%7C21782239%7C22318540%7C7597815>

## Safety and Regulatory Compliance

The following table lists the safety and regulatory compliance of CloudEngine switches.

Certification Category	Description
Safety	<ul style="list-style-type: none"> <li>• EN 60950-1</li> <li>• EN 60825-1</li> <li>• EN 60825-2</li> <li>• UL 60950-1</li> <li>• CSA-C22.2 No. 60950-1</li> <li>• IEC 60950-1</li> <li>• AS/NZS 60950-1</li> <li>• GB4943</li> </ul>
Electromagnetic Compatibility (EMC)	<ul style="list-style-type: none"> <li>• EN 300386</li> <li>• EN 55032: CLASS A</li> <li>• EN 55024</li> <li>• IEC/EN 61000-3-2</li> <li>• IEC/EN 61000-3-3</li> <li>• FCC 47CFR Part15 CLASS A</li> <li>• ICES-003: CLASS A</li> <li>• CISPR 32: CLASS A</li> <li>• CISPR 24</li> <li>• AS/NZS CISPR32</li> <li>• VCCI- CISPR32: CLASS A</li> <li>• GB9254 CLASS A</li> </ul>
Environment	<ul style="list-style-type: none"> <li>• 2011/65/EU EN 50581</li> <li>• 2012/19/EU EN 50419</li> <li>• (EC) No.1907/2006</li> <li>• GB/T 26572</li> <li>• ETSI EN 300 019-1-1</li> <li>• ETSI EN 300 019-1-2</li> <li>• ETSI EN 300 019-1-3</li> <li>• ETSI EN 300 753 GR63</li> </ul>

Note

EMC: electromagnetic compatibility

CISPR: International Special Committee on Radio Interference

EN: European Standard

ETSI: European Telecommunications Standards Institute

CFR: Code of Federal Regulations

FCC: Federal Communication Commission

IEC: International Electrotechnical Commission

AS/NZS: Australian/New Zealand Standard

VCCI: Voluntary Control Council for Interference

UL: Underwriters Laboratories

CSA: Canadian Standards Association

## Supported MIBs

For details about the MIB information, visit

<https://support.huawei.com/hedex/hdx.do?docid=EDOC1100136525&lang=en&idPath=24030814%7C21782165%7C21782239%7C22318540%7C7597815>.

## Optical Transceivers and Cable

For details about the optical transceivers and cables information, visit

<https://e.huawei.com/en/material/networking/dcs/switch/f6d91cf16df0474998087676a33fd41e>.

## Ordering Information

Mainframe	
CE6857E-48T6CQ	CE6857E-48T6CQ switch (48*10GE RJ45, 6*100GE QSFP28, without fan and power modules)
CE6857E-48T6CQ-B	CE6857E-48T6CQ switch (48*10GE RJ45, 6*100GE QSFP28, 2*AC power modules, 4*fan modules, port-side intake)
CE6857E-48T6CQ-F	CE6857E-48T6CQ switch (48*10GE RJ45, 6*100GE QSFP28, 2*AC power modules, 4*fan modules, port-side exhaust)

### Fan Tray

Model	Description	Applicable Product
FAN-031A-F	FAN-031A-F, Fan box (F, FAN panel side intake )	CE6857E-48T6CQ
FAN-031A-B	Fan box (B, FAN panel side exhaust)	CE6857E-48T6CQ

### Power

Model	Description	Applicable Product
PAC600S12-CB	600W AC Power Module(Back to Front, Power panel side exhaust)	CE6857E-48T6CQ
PAC600S12-CF	600W AC Power Module(Front to Back,Power panel side intake)	CE6857E-48T6CQ
PDC1000S12-DF	1000W DC Power Module (Front to Back,Power panel side intake)	CE6857E-48T6CQ
PDC1000S12-DB	1000W DC Power Module (Back to Front,Power panel side exhaust)	CE6857E-48T6CQ
PHD1K2S12-DB	1200W HVDC Power Module (Back to Front, Power panel side exhaust)	CE6857E-48T6CQ

Software	
N1-CE68LIC-CFFD	N1-CloudFabric Foundation SW License for CloudEngine 6800
N1-CE68CFFD-SnS1Y	N1-CloudFabric Foundation SW License for CloudEngine 6800-SnS-1 Year
N1-CE68LIC-CFAD	N1-CloudFabric Advanced SW License for CloudEngine 6800
N1-CE68CFAD-SnS1Y	N1-CloudFabric Advanced SW License for CloudEngine -SnS -1 Year
N1-CE68LIC-CFPM	N1-CloudFabric Premium SW License for CloudEngine 6800
N1-CE68CFPM-SnS1Y	N1-CloudFabric Premium SW License for CloudEngine 6800 -SnS-Year
N1-CE-F-LIC-MDCA	N1-CloudEngine Data Center Switch Multi-cloud Multi-DC Value-added Package - Fixed
N1-CEFMDCA -SnS1Y	N1-CloudEngine Data Center Switch Multi-cloud Multi-DC Value-added Package, Per Fixed device -SnS-Year

## Networking and Application

### Data Center Applications

On a typical data center network, CloudEngine 6857E series switches work as TOR switches and connect to CloudEngine16800, CloudEngine 12800 or CloudEngine 8800 core switches using 40GE/100GE ports, building an end-to-end 40GE/100GE full-mesh network. The core and TOR switches use fabric technologies such as VXLAN to build a non-blocking large Layer 2 network, which allows for large-scale VM migration and flexible service deployment.

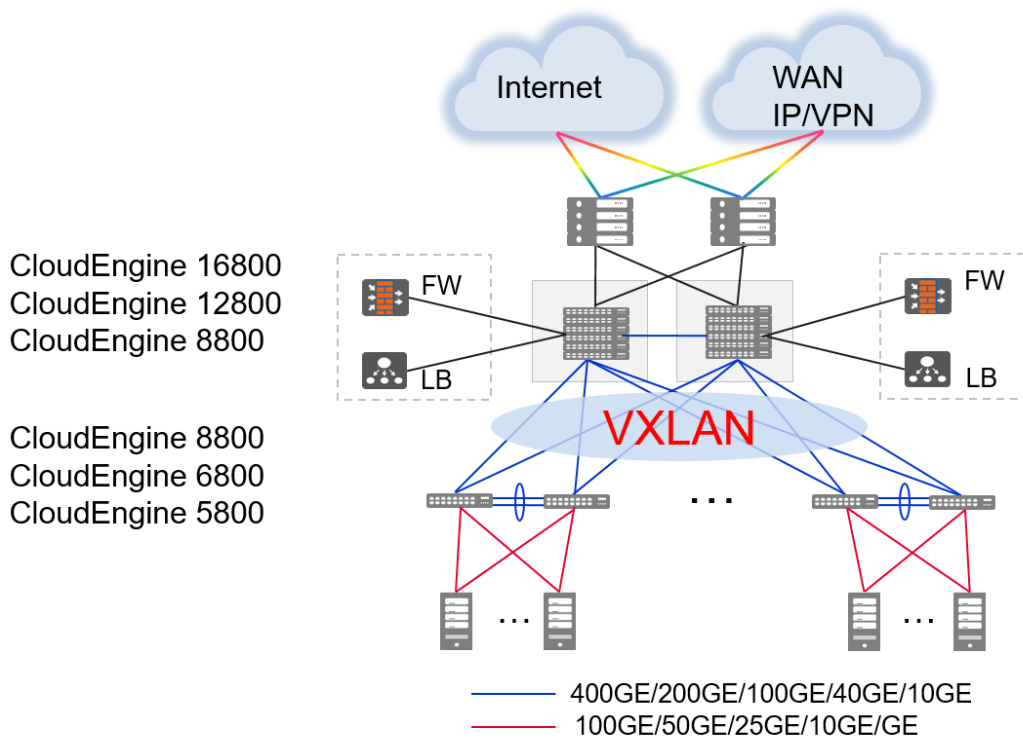

Note: VXLAN can also be used on campus networks to support flexible service deployment in different service areas.

**Copyright © Huawei Technologies Co., Ltd. 2021. All rights reserved.**

No part of this document may be reproduced or transmitted in any form or by any means without prior written consent of Huawei Technologies Co., Ltd.

#### **Trademarks and Permissions**



HUAWEI and other Huawei trademarks are trademarks of Huawei Technologies Co., Ltd.

All other trademarks and trade names mentioned in this document are the property of their respective holders.

#### **Notice**

The purchased products, services and features are stipulated by the contract made between Huawei and the customer. All or part of the products, services and features described in this document may not be within the purchase scope or the usage scope. Unless otherwise specified in the contract, all statements, information, and recommendations in this document are provided "AS IS" without warranties, guarantees or representations of any kind, either express or implied.

The information in this document is subject to change without notice. Every effort has been made in the preparation of this document to ensure accuracy of the contents, but all statements, information, and recommendations in this document do not constitute a warranty of any kind, express or implied.

#### **Huawei Technologies Co., Ltd.**

Address: Huawei Industrial Base Bantian, Longgang Shenzhen 518129 People's Republic of China

Website: [www.huawei.com](http://www.huawei.com)